

Glass Door Display

# GDM-33-HC-LD

 Upright Retail Merchandiser Refrigerator, 2 Full Glass Slide Doors



Dimensions		Build		Technical	
External Width (mm)	1004	Door Description	2 Full Glass Slide Doors	Temperature Holding	0.5 : 3.3°C
External Depth (mm)	753	Exterior Construction	Stainless Steel/Aluminium front, Aluminium sides and rear (Black or White Powder Coat option)	Refrigerant	R290
External Height (mm)	1998	Interior Construction	White coated aluminium, stainless steel base	Voltage / Frequency / Phase	220-240V/50-60Hz/1
Exclusions	Depth does not include 10 mm for door handle or 13 mm for rear access panel.	Air Intake Position	Front	Amps	2.2
Net Volume (Litres)	636	Ventilation Position	Rear	Wattage	506
Gross Volume (Litres)	932	Clearance Required	26 mm rear, zero sides	Temperature Class	M1
Display Area (m <sup>2</sup> )	0.94	Cord Length (Meters)	2.74	Operating Statement	Tested at 25°C, 60% RH, per 'Refrigerators with a Direct Sales Function' for perishable food merchandising.
Supplied Shelves	8	Internal Lighting	LED	Testing Standard	EN 23953
Shelf Size (L x D mm)	439 x 537	Standard w/ Locks	Not Standard. Options available.	EEC	B
Internal Net Height (mm)	1300			EEL	17.9
Unpackaged Weight (kg)	157			kWh/24hr	3.996
Packaged Weight (kg)	168			kWh/Annum	1459
Packaged Dimensions (W x D x H mm)	1093 x 839 x 2134			Defrost Type	Auto
Supplied Supports	Leg Levellers (Castors supplied separate)				



Specifications subject to change without notice.  
 Technical data above related to energy use based on testing of 50Hz or Dual Frequency models  
 Chart dimensions rounded up to the next whole millimeter (inches rounded up to the 1/8")

UK & Ireland [0800 783 2049](tel:08007832049)  
 EMEA [+41 61 563 07 05](tel:+41615630705)  
 Australia [+61 2 9619 9999](tel:+61296199999)

[TFIUK@truemfg.com](mailto:TFIUK@truemfg.com)  
[TrueCHCustomerService@truemfg.com](mailto:TrueCHCustomerService@truemfg.com)  
[TrueRefAus@truemfg.com](mailto:TrueRefAus@truemfg.com)



# GDM-33-HC-LD

Upright Retail Merchandiser Refrigerator, 2 Full Glass Slide Doors

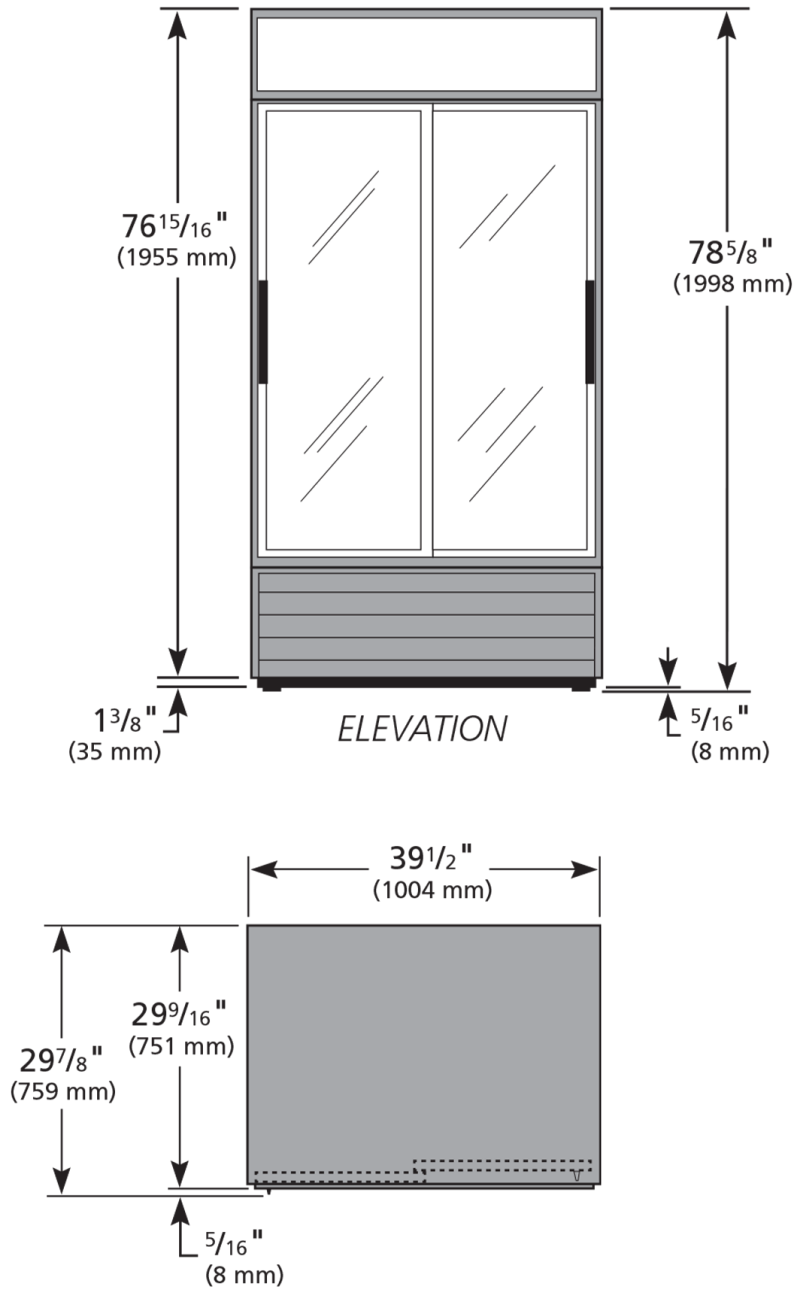

Specifications subject to change without notice.  
Technical data above related to energy use based on testing of 50Hz or Dual Frequency models  
Chart dimensions rounded up to the next whole millimeter (inches rounded up to the 1/8")

UK & Ireland 0800 783 2049  
EMEA +41 61 563 07 05  
Australia +61 2 9619 9999

[TFIUK@truemfg.com](mailto:TFIUK@truemfg.com)  
[TrueCHCustomerService@truemfg.com](mailto:TrueCHCustomerService@truemfg.com)  
[TrueRefAus@truemfg.com](mailto:TrueRefAus@truemfg.com)

