

Master Series Electric XPress Grill

Project _____
 Item _____
 Quantity _____
 CSI Section 11400
 Approved _____
 Date _____

Models

- XPE12
- XPE12CE



Model XPE12
Shown with straight grease cans



Standard Features

- Programmable control for each cooking lane precisely controls:
 - Automatic lifting and lowering of upper platen
 - Cooking gap and time
- EasyTouch™ screen design is simple and intuitive with Press and Go interface
- Advanced temperature control, smart anticipation versus on-off
 - Eliminates temperature overshoot and undershoot
 - Increases temperature uniformity with five independently controlled heat zones -- three on plate and two on platen
- Recipes are programmed by setting grill temperature, platen temperature, cooking gap up to 2 inches (5 cm) and cook time
- USB interface to update menus
- User interface provides advanced diagnostics and error logging for ease of service and increased first-time fix
- Stainless steel front, top and sides
- Towel bar with bun pan lip
- Stainless steel dual side grease collectors
- Swivel casters (4) with front brakes
- IPX4 water resistant rating
- Two-year limited parts and labor (USA & Canada)

Options & Accessories

- Grease cans are available with
 - straight sides for minimum space
 - flared sides to hold optional tool holders
- Optional tool holders
 - 4-inch spatula
 - 6-inch scrapper
 - 7-inch wiper

Specifications

The XPress Grill's upper and lower grill plates cook both sides simultaneously, reducing cook times by up to 50%. Upper grill plate is automatically raised and lowered by a lift system powered by a quiet actuator.

Lower griddle plate made of 3/4" (19mm) thick carbon steel, machine ground and highly polished.

Lower grill plate heated by three electric heating elements.

Upper platen heated by nickel plated cast aluminum electric heating elements.

Electric top heater provided with replaceable quick release Teflon sheets. Available in three phase power for Delta or Wye electrical systems.

Voltage sensing and power management automatically adjusts power to electrical system voltage.

Available with CSA or CE approvals. All have NSF approval.

Installation with zero clearance against non-combustible surfaces.



Master Series Electric XPress Grill

Master Series Electric XPress Grill

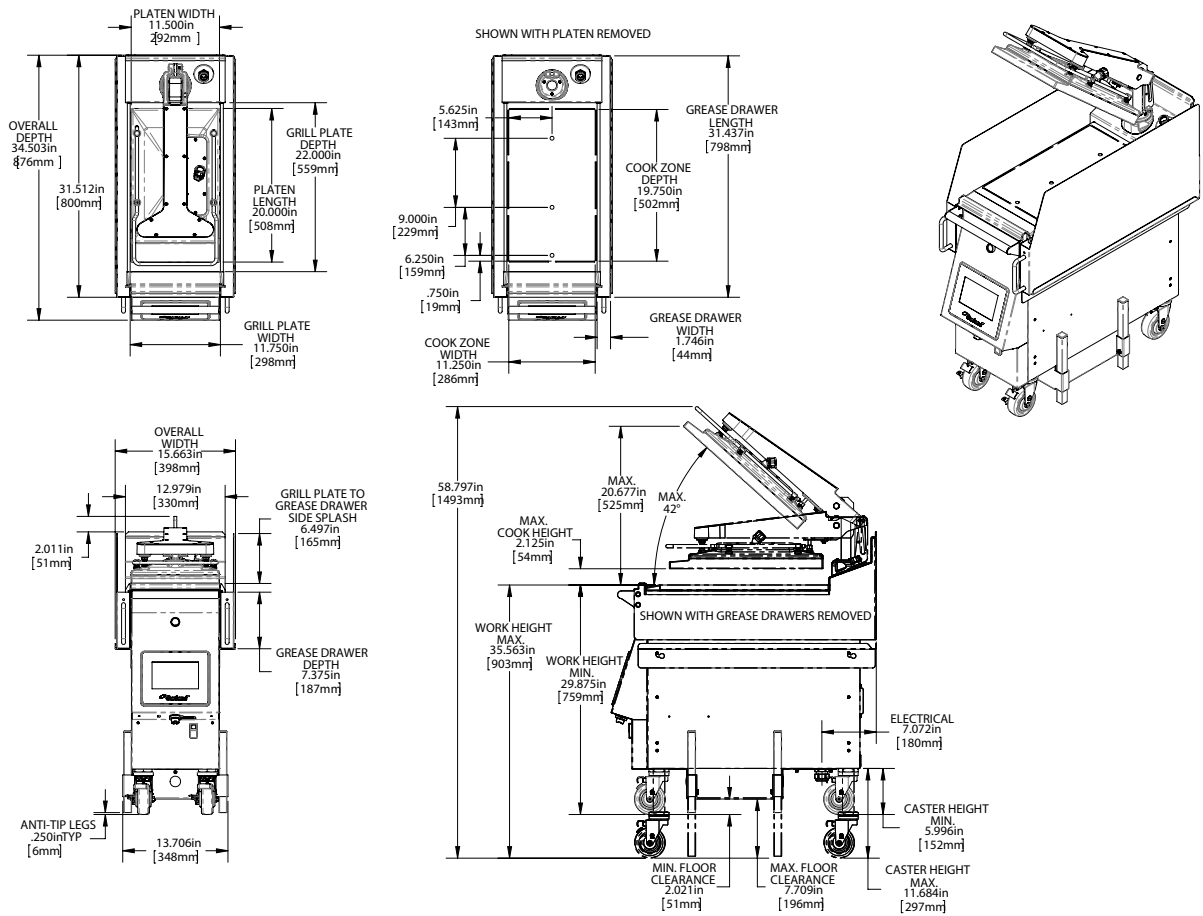

Electrical Input Specification -DELTA					
XPE12 CSA Models - Delta					
Model	Volts 3 Ph 50/60 Hz	Total Current (A)			Power (kW)
		L1	L2	L3	
1 Platen	200V	23.6	26.5	25.8	8.0
	208V	23.3	26.2	25.6	8.1
	220V	22.0	23.7	24.1	7.9
	230V	21.2	22.6	23.5	7.9
	240V	21.0	22.5	23.4	7.9

Electrical Input Specification - WYE					
XPE12 CE Models - WYE					
Model	Volts 3 Ph 50/60 Hz	Total Current (A)			Power (kW)
		L1	L2	L3	
1 Platen	220V/380V	12.6	15.2	13.8	7.9
	230V/400V	11.8	14.6	13.8	7.9
	240V/415V	11.8	14.6	13.8	7.9

Welbilt reserves the right to make changes to the design or specifications without prior notice.

Garland Commercial Ranges Ltd.
 1177 Kamato Road,
 Mississauga, Ontario
 L4W 1X4 CANADA

General Inquires 1-905-624-0260
 USA Sales, Parts and Service 1-800-424-2411
 Canadian Sales 1-888-442-7526
 Canada or USA Parts/Service 1-800-427-6668

www.garland-group.com
 7175_XPE12
 04/19